

Queen Mary School Hainan
Queen Mary University of London

QHP5701 Exploratory Data Analysis

System: Convolution

Nikesh Bajaj, PhD
Lecturer in Data Science,
Queen Mary University of London
nikesh.bajaj@qmul.ac.uk
<https://nikeshbajaj.in>

Contents

- Continues-time Systems
- Discreet-time Systems
- Properties
- Convolution, Filtering

#Ref: Chapter 1, Oppenheim

#Ref: Chapter 2, Oppenheim

Linear or Nonlinear

$$y(t) = \int_{-\infty}^{3t} x(\tau) d\tau$$

Systems

Linear/Non-linear

Memory/Memoryless?

Causal/Non-causal?

Time Invariant / Time variant?

Stable/Unstable?

Invertible/Non-invertible?

$$y(t) = \int_{-\infty}^{3t} x(\tau) d\tau$$

Systems

$$S_1 : y_1(n) = 2x_1(n) + 4x_1(n - 1)$$

$$S_2 : y_2(n) = x_2(n - 2) + 0.5x_2(n)$$

Series Conn.

$$S : S_1 \rightarrow S_2 ?$$

$$S : S_2 \rightarrow S_1 ?$$

Systems

- Linear/Non-linear
 - Memory/Memoryless?
 - Causal/Non-causal?
 - Time Invariant / Time variant?
 - Stable/Unstable?
 - Invertible/Non-invertible?
-
- Output of system for $x(n) = A\delta(n)$

$$y_1(n) = x_1(n)x(n - 1)$$

Impulse Response

Unit Impulse Response of the system

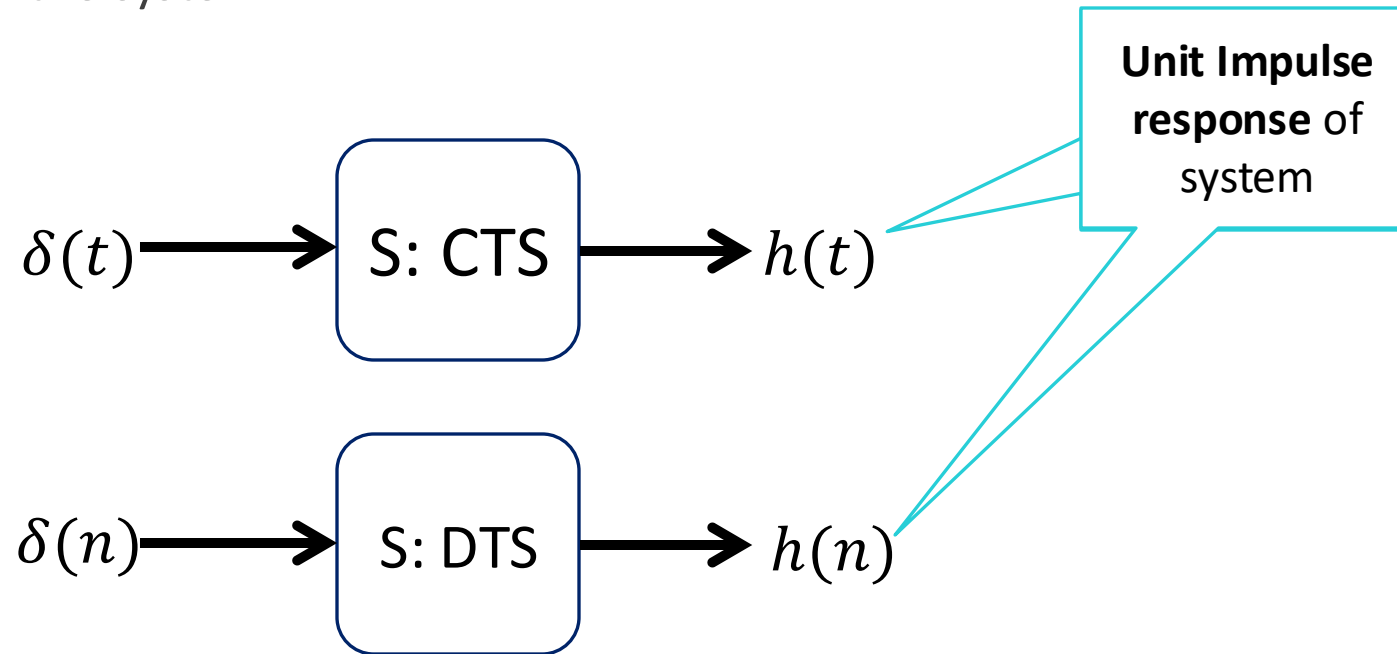

Impulse Response

Find Impulse response of the systems, also check they are LTI?

$$y_1(n) = 2x_1(n) + 4x_1(n - 1)$$

$$y(t) = \int_{-\infty}^{\infty} x(t)dt$$

$$y(t) = \int_{-\infty}^t x(t)dt$$

Impulse Response

Convolution

Convolution sum

$$y(n) = \sum_{k=-\infty}^{\infty} x(k)h(n-k)$$

$$y(n) = x(n) * h(n)$$

$$y(t) = \int_{-\infty}^{\infty} x(\tau)h(t-\tau)d\tau$$

$$y(t) = x(t) * h(t)$$

Convolution

$$y(n) = h(n) * x(n)$$

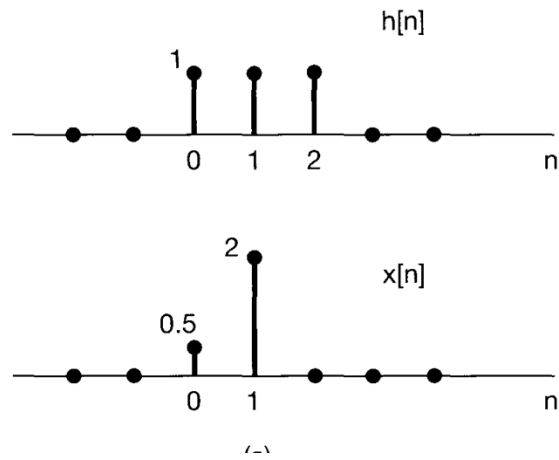

Convolution

$$y(n) = h(n) * x(n)$$

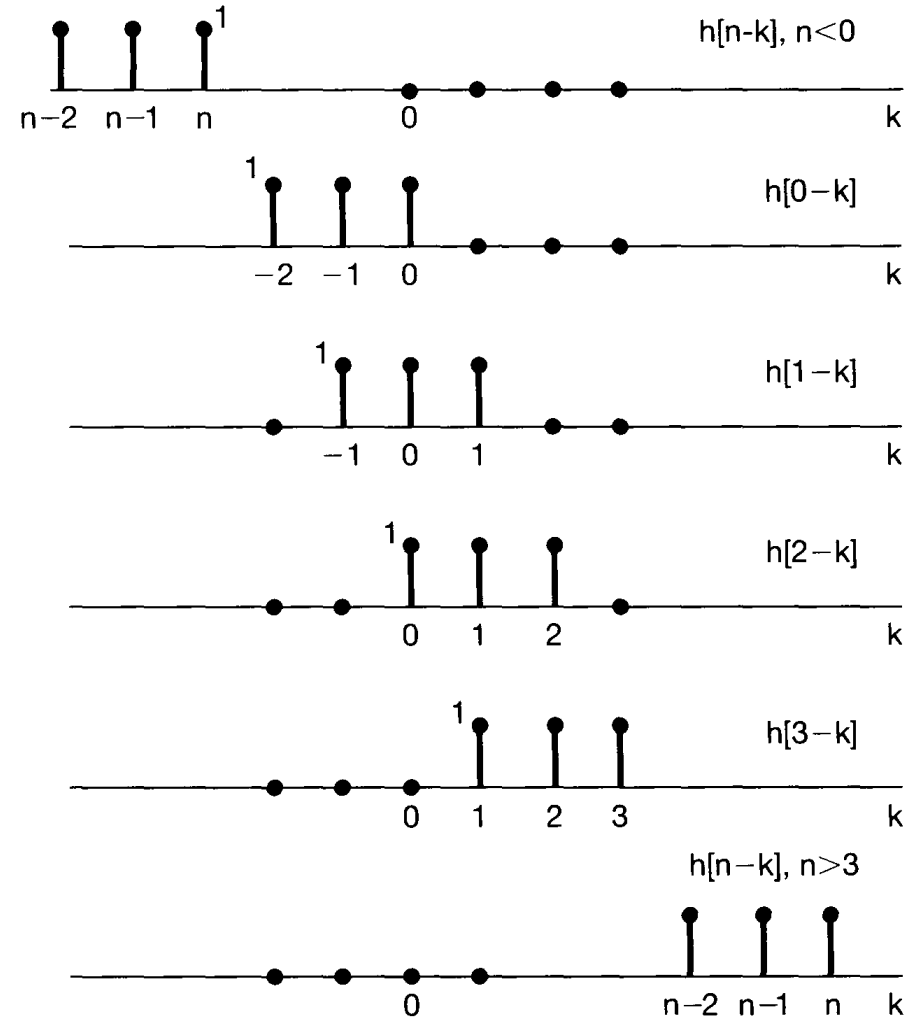
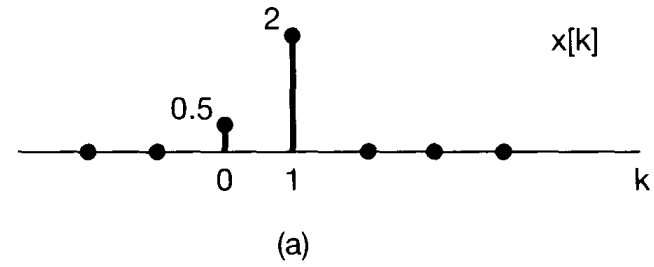
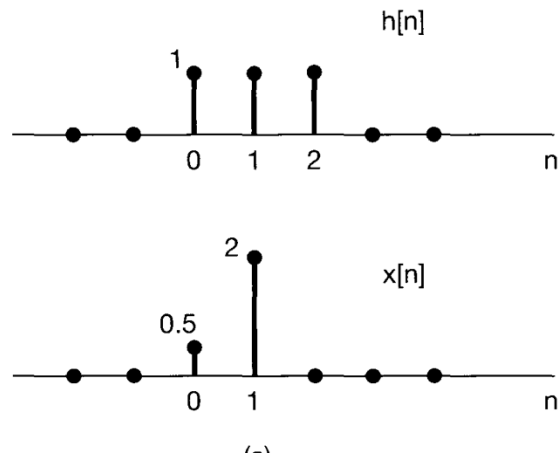

Convolution

$$x(n) = \alpha^n u(n)$$

$$h(n) = u(n)$$

Convolution

$$\begin{aligned}x(n) &= 1, && \text{for } 0 \leq n \leq 4 \\h(n) &= \alpha^n, && \text{for } 0 \leq n \leq 6, \quad \alpha > 1\end{aligned}$$

Convolution

$$\begin{aligned}x(n) &= 1, & \text{for } 0 \leq n \leq 4 \\h(n) &= \alpha^n, & \text{for } 0 \leq n \leq 6, \quad \alpha > 1\end{aligned}$$

$$y[n] = \begin{cases} 0, & n < 0 \\ \frac{1 - \alpha^{n+1}}{1 - \alpha}, & 0 \leq n \leq 4 \\ \frac{\alpha^{n-4} - \alpha^{n+1}}{1 - \alpha}, & 4 < n \leq 6 \\ \frac{\alpha^{n-4} - \alpha^7}{1 - \alpha}, & 6 < n \leq 10 \\ 0, & 10 < n \end{cases}$$

Convolution

$$x(n) = [1, -1, 2, 1]$$

$$h(n) = [1, -1]$$

$$x(n) = [1, -1, 2, 1]$$

$$h(n) = [1, -1]$$

$$x(n) = [1, -1, 2, 1]$$

$$h(n) = [1, -1]$$

Convolution

$$x(n) = [1, -1, 2, 1]$$

$$h(n) = [1, -1]$$

Convolution

$$x(n) = [1, 1, 2, 1]$$

$$h(n) = [1, -1]$$

$$x(n) = [1, 1, 2, 1]$$

$$h(n) = [1, -1]$$

$$x(n) = [1, -1, 5, -2, 0, 1]$$

$$h(n) = [1, 1]$$

Convolution

$$x(t) = e^{-at}$$

$$h(t) = u(t)$$

Convolution

$$x(t) = e^{-at}$$

$$h(t) = u(t)$$

Convolution: demo

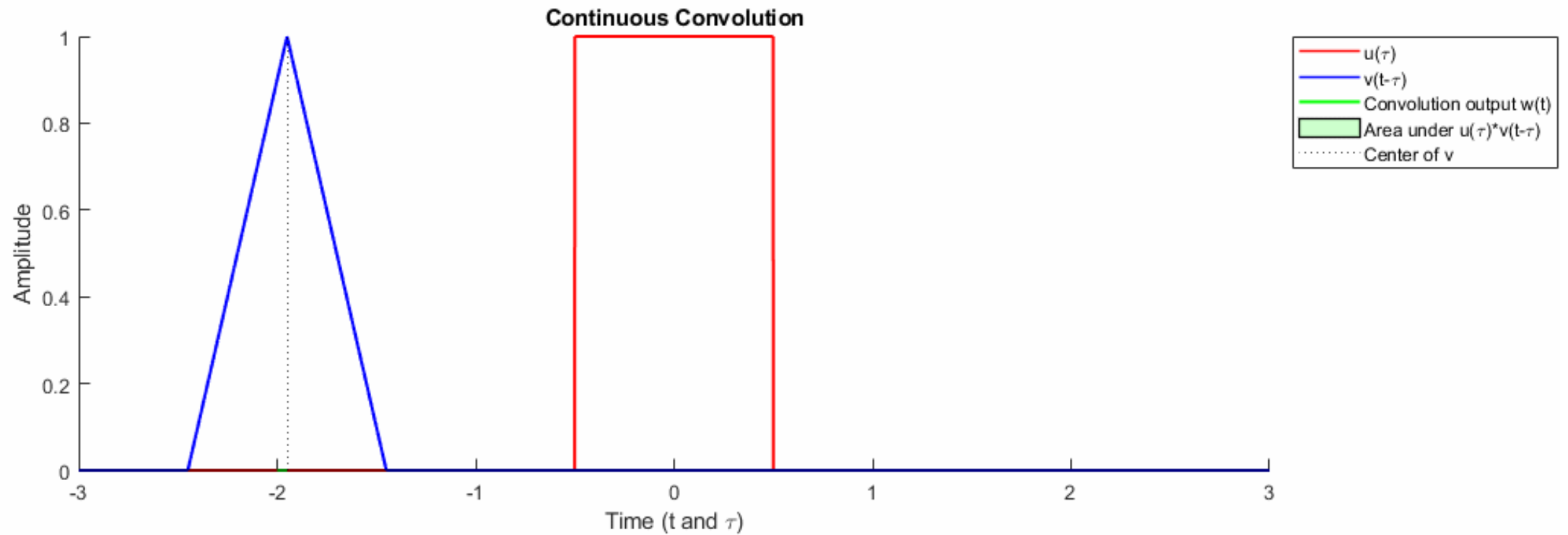

Convolution: demo

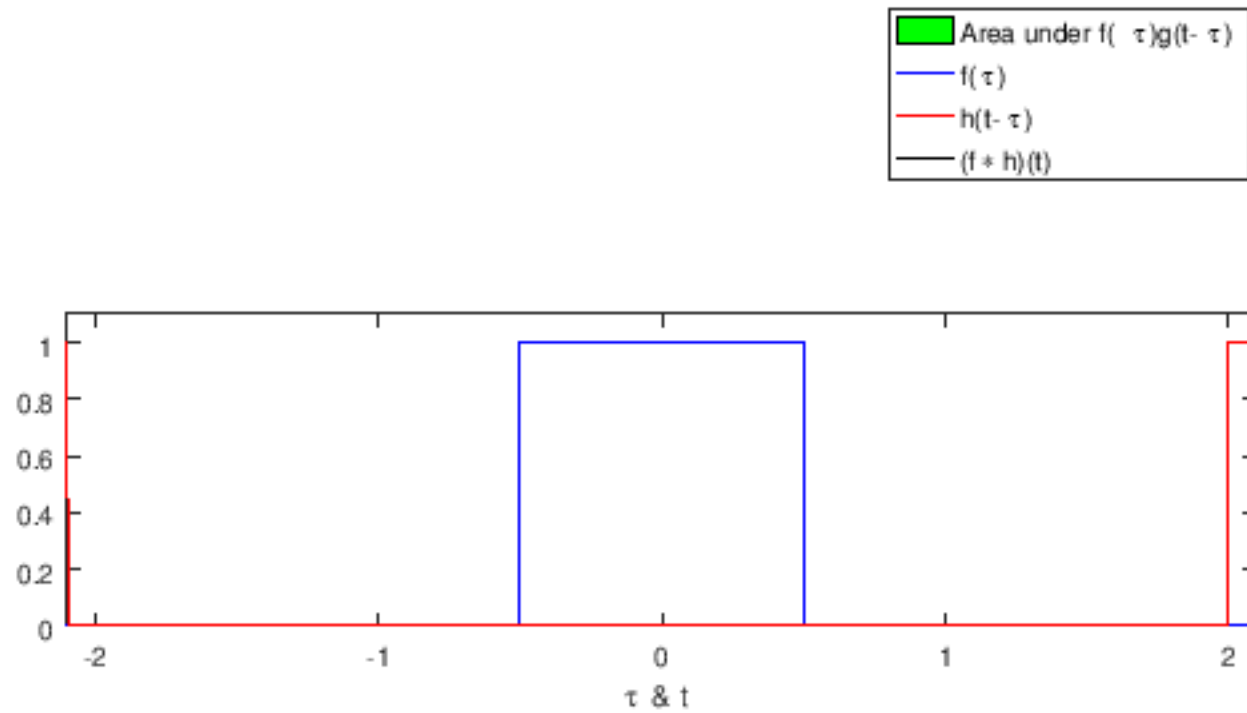

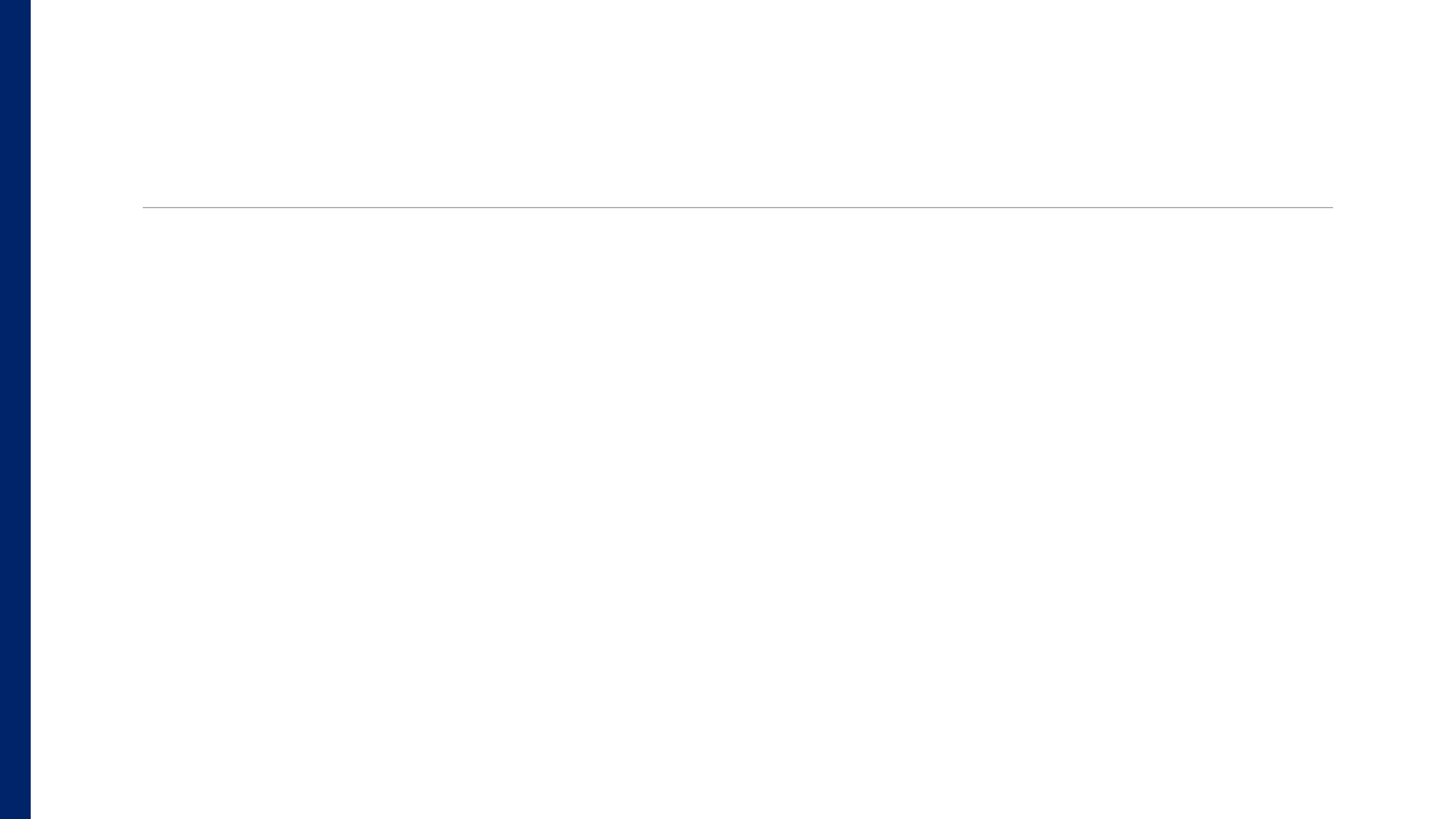

$$x(t) = \begin{cases} 1, & 0 < t < T \\ 0, & \text{otherwise} \end{cases}$$

Convolution

$$x(t) = 1, \quad \text{for } 0 < t < T \text{ else } 0$$

$$h(t) = t, \quad \text{for } 0 < t < 2T \text{ else } 0$$

$$x(t) = \begin{cases} 1, & 0 < t < T \\ 0, & \text{otherwise} \end{cases}$$

Convolution

$$x(t) = 1, \quad \text{for } 0 < t < T \text{ else } 0$$

$$h(t) = t, \quad \text{for } 0 < t < 2T \text{ else } 0$$

Convolution

$$y(t) = \begin{cases} 0, & t < 0 \\ \frac{1}{2}t^2, & 0 < t < T \\ Tt - \frac{1}{2}T^2, & T < t < 2T \\ -\frac{1}{2}t^2 + Tt + \frac{3}{2}T^2, & 2T < t < 3T \\ 0, & 3T < t \end{cases},$$

$$x(t) = 1, \quad \text{for } 0 < t < T \text{ else } 0$$

$$h(t) = t, \quad \text{for } 0 < t < 2T \text{ else } 0$$

Convolution

$$x(t) = e^{-at}$$

$$h(t) = u(t)$$

Convolution with $\delta(t)$

$$x(t) * \delta(t) = x(t)$$

$$x(t) * \delta(t - \tau) = x(t - \tau)$$

$$x(t - k) * \delta(t) = x(t - k)$$

$$x(t - k) * \delta(t - \tau) = x(t - \tau - k)$$

Convolution with $\delta(t)$

Convolution

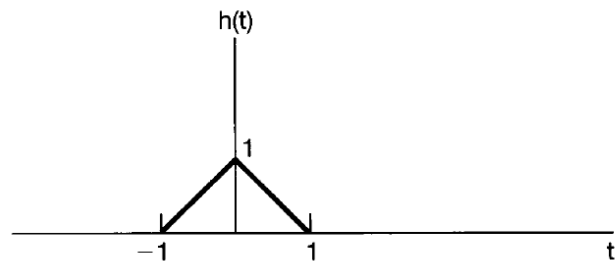

(a)

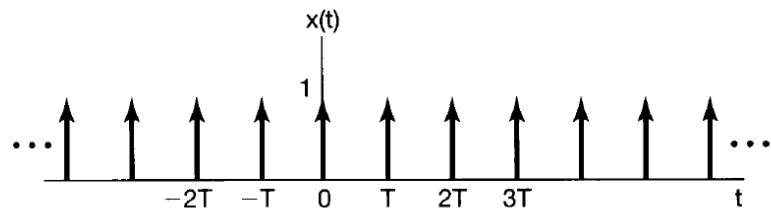

Convolution: Properties

$$y(n) = \sum_{k=-\infty}^{\infty} x(k)h(n-k)$$

$$y(n) = \sum_{k=-\infty}^{\infty} x(k-r)h(n)$$

$$y(n) = h(n) * x(n)$$

$$y(n) = x(n) * h(n)$$

$$\begin{aligned}y(n) &= x(n) * (h_1(n) * h_2(n)) \\ &= x(n) * h_2(n) * h_1(n) \\ &= h_1(n) * h_2(n) * x(n)\end{aligned}$$

$$y(n) = x(n) * [h_1(n) + h_2(n)]$$

$$x(t) * \delta(t) = x(t)$$

$$x(t) * \delta(t - \tau) = x(t - \tau)$$

$$x(t - k) * \delta(t) = x(t - k)$$

$$x(t - k) * \delta(t - \tau) = x(t - \tau - k)$$

Convolution: Example

Systems: Block Diagrams: CTS

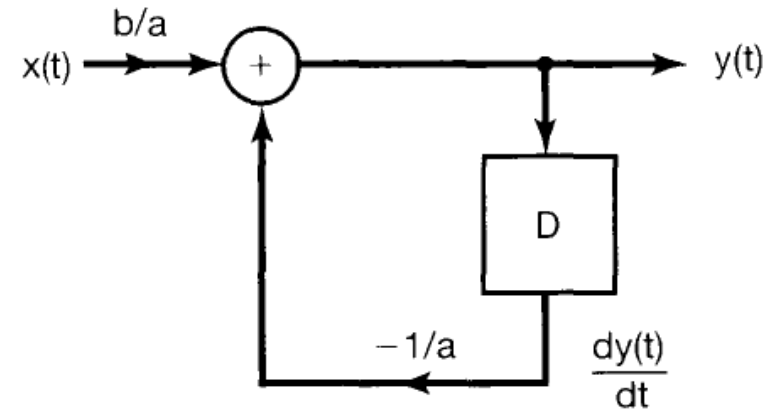
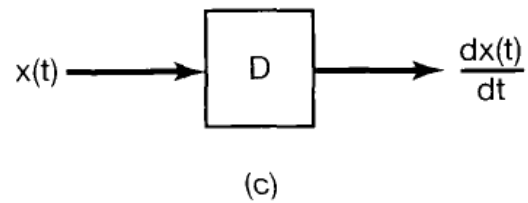
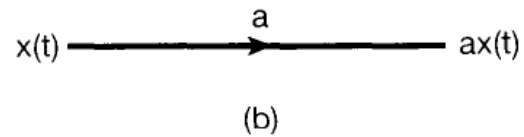
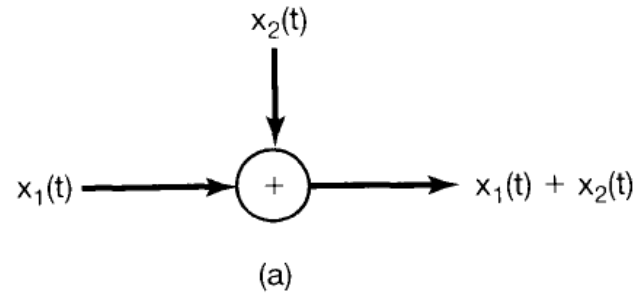
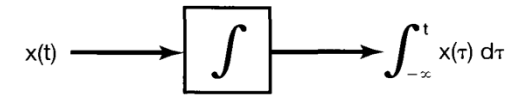

Systems: Block Diagrams: DTS

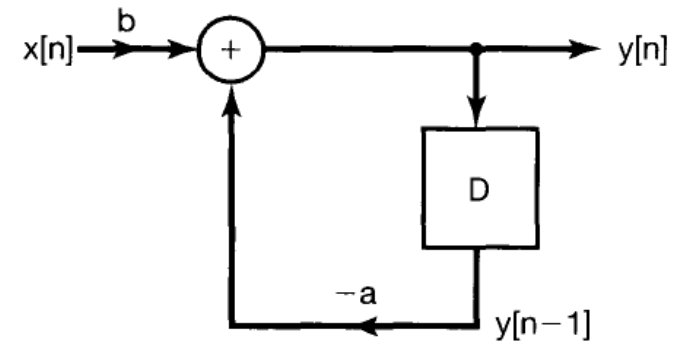
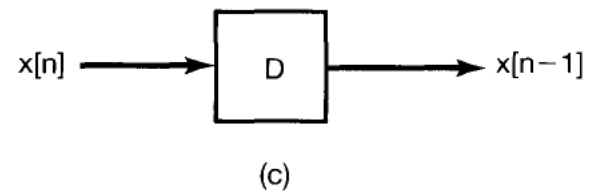
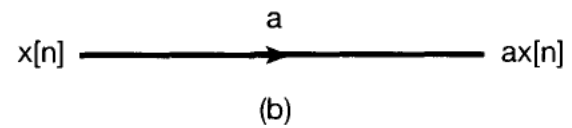
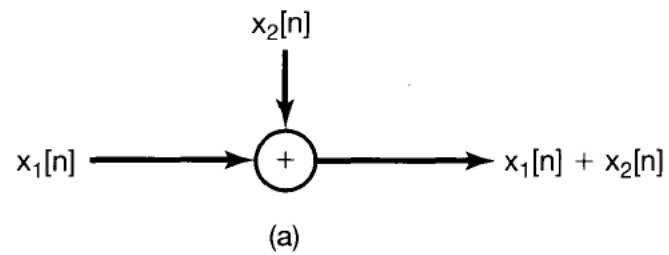

System Properties: impulse response

- Memoryless?

$$h(t) = K\delta(t), \quad h(n) = K\delta(n)$$

- Invertible?

$$h(t) * h_1(t) = \delta(t)$$

$$h(n) = u(n)$$

- Causal?

$$h(t) = 0 \text{ for } t < 0$$

- Stable? Sufficient/Necessary Condition for stability

$$\sum_k |h(k)| < \infty$$
$$\int_{-\infty}^{\infty} |h(t)| dt < \infty$$

System Properties

Convolution & Fourier

Convolution in Time domain and multiplication in frequency domain

$$y(t) = x(t) * h(t)$$
$$Y(j\omega) = X(j\omega)H(j\omega)$$

$$y(t) = x(t)h(t)$$
$$Y(j\omega) = X(j\omega) * H(j\omega)$$

Convolution & Fourier

$$h(t) = \delta(t - t_0)$$

$$y(t) = ?$$

$$H(j\omega) = e^{-j\omega t_0}$$

$$Y(j\omega) = e^{-j\omega t_0} X(j\omega)$$

System: Transfer Function

$h(t)$ - *Impulse Response of system*

$H(j\omega)$ - *Transfer Function of system*

$$H(j\omega) = \frac{Y(j\omega)}{X(j\omega)}$$

$$y(t) = x(t) * h(t)$$
$$Y(j\omega) = X(j\omega)H(j\omega)$$

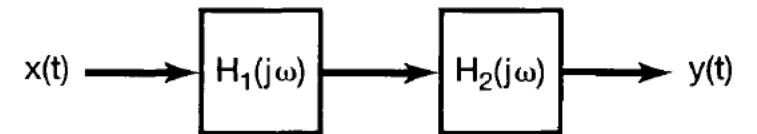

(a)

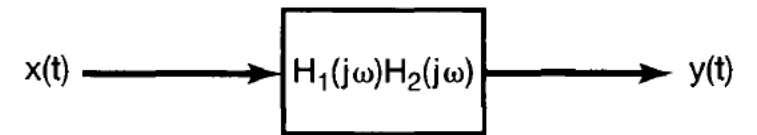

(b)

Convolution & Fourier: diff. Eq.

$$\frac{dy(t)}{dt} + 2y(t) = x(t)$$

$$h(t) = ?$$

Convolution & Fourier: diff. Eq.

$$\frac{dy(t)}{dt} + 2y(t) = x(t)$$

$$h(t) = ?$$

$$x(t) = u(t)$$

$$y(t) = ?$$

Convolution & Fourier: diff. Eq.

Convolution, Fourier: Spectral Filtering

$$H(j\omega) = \begin{cases} 1, & |\omega| < \omega_c \\ 0, & |\omega| > \omega_c \end{cases}$$

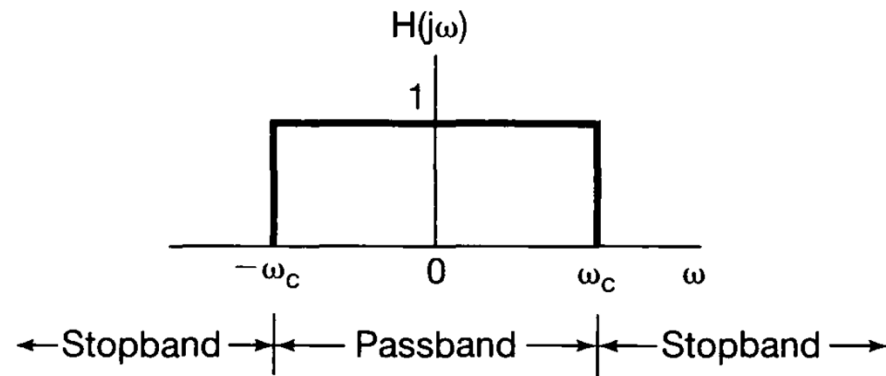

Convolution, Fourier: Spectral Filtering

$$h(t) = \frac{\sin(\omega_c t)}{\pi t}$$

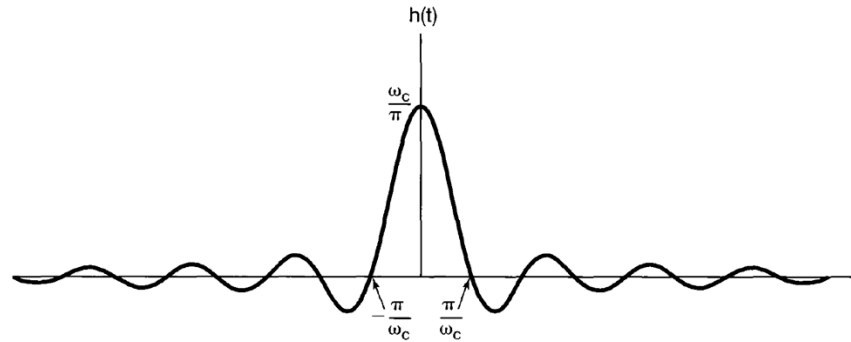

$$y(t) = x(t) * h(t)$$

Spectral Filtering

Spectral Filtering

Useful:

$$\sum_{k=0}^{\infty} \alpha^k = \frac{1}{1-\alpha} \text{ for } |\alpha| < 1$$

$$\sum_{k=0}^M \alpha^k = \frac{1-\alpha^{M+1}}{1-\alpha} \text{ for } |\alpha| < 1$$

Systems: Exercise

1.17. Consider a continuous-time system with input $x(t)$ and output $y(t)$ related by

$$y(t) = x(\sin(t)).$$

- (a) Is this system causal?
- (b) Is this system linear?

1.18. Consider a discrete-time system with input $x[n]$ and output $y[n]$ related by

$$y[n] = \sum_{k=n-n_0}^{n+n_0} x[k],$$

where n_0 is a finite positive integer.

- (a) Is this system linear?
- (a) Is this system time-invariant?
- (c) If $x[n]$ is known to be bounded by a finite integer B (i.e., $|x[n]| < B$ for all n), it can be shown that $y[n]$ is bounded by a finite number C . We conclude that the given system is stable. Express C in terms of B and n_0 .

Systems: Exercise

1.19. For each of the following input-output relationships, determine whether the corresponding system is linear, time invariant or both.

(a) $y(t) = t^2 x(t - 1)$ (b) $y[n] = x^2[n - 2]$

(c) $y[n] = x[n + 1] - x[n - 1]$ (d) $y[n] = \mathcal{O}d\{x(t)\}$

1.20. A continuous-time linear system S with input $x(t)$ and output $y(t)$ yields the following input-output pairs:

$$x(t) = e^{j2t} \xrightarrow{S} y(t) = e^{j3t},$$

$$x(t) = e^{-j2t} \xrightarrow{S} y(t) = e^{-j3t}.$$

(a) If $x_1(t) = \cos(2t)$, determine the corresponding output $y_1(t)$ for system S .

(b) If $x_2(t) = \cos(2(t - \frac{1}{2}))$, determine the corresponding output $y_2(t)$ for system S .

Systems: Exercise

- (1) Memoryless
- (2) Time invariant
- (3) Linear
- (4) Causal
- (5) Stable

(a) $y(t) = x(t - 2) + x(2 - t)$

(b) $y(t) = [\cos(3t)]x(t)$

(c) $y(t) = \int_{-\infty}^{2t} x(\tau)d\tau$

(d) $y(t) = \begin{cases} 0, & t < 0 \\ x(t) + x(t - 2), & t \geq 0 \end{cases}$

(e) $y(t) = \begin{cases} 0, & x(t) < 0 \\ x(t) + x(t - 2), & x(t) \geq 0 \end{cases}$

(f) $y(t) = x(t/3)$

(g) $y(t) = \frac{dx(t)}{dt}$

1.28. Determine which of the properties listed in Problem 1.27 hold and which do not hold for each of the following discrete-time systems. Justify your answers. In each example, $y[n]$ denotes the system output and $x[n]$ is the system input.

(a) $y[n] = x[-n]$

(b) $y[n] = x[n - 2] - 2x[n - 8]$

(c) $y[n] = nx[n]$

(d) $y[n] = \mathcal{E}_v\{x[n - 1]\}$

(e) $y[n] = \begin{cases} x[n], & n \geq 1 \\ 0, & n = 0 \\ x[n + 1], & n \leq -1 \end{cases}$

(f) $y[n] = \begin{cases} x[n], & n \geq 1 \\ 0, & n = 0 \\ x[n], & n \leq -1 \end{cases}$

(g) $y[n] = x[4n + 1]$

Systems: Exercise

1.30. Determine if each of the following systems is invertible. If it is, construct the inverse system. If it is not, find two input signals to the system that have the same output.

(a) $y(t) = x(t - 4)$

(b) $y(t) = \cos[x(t)]$

(c) $y[n] = nx[n]$

(d) $y(t) = \int_{-\infty}^t x(\tau) d\tau$

(e) $y[n] = \begin{cases} x[n - 1], & n \geq 1 \\ 0, & n = 0 \\ x[n], & n \leq -1 \end{cases}$

(f) $y[n] = x[n]x[n - 1]$

(g) $y[n] = x[1 - n]$

(h) $y(t) = \int_{-\infty}^t e^{-(t-\tau)} x(\tau) d\tau$

(i) $y[n] = \sum_{k=-\infty}^n (\frac{1}{2})^{n-k} x[k]$

(j) $y(t) = \frac{dx(t)}{dt}$

(k) $y[n] = \begin{cases} x[n + 1], & n \geq 0 \\ x[n], & n \leq -1 \end{cases}$

(l) $y(t) = x(2t)$

(m) $y[n] = x[2n]$

(n) $y[n] = \begin{cases} x[n/2], & n \text{ even} \\ 0, & n \text{ odd} \end{cases}$

Convolution: Exercise

2.1. Let

$$x[n] = \delta[n] + 2\delta[n - 1] - \delta[n - 3] \quad \text{and} \quad h[n] = 2\delta[n + 1] + 2\delta[n - 1].$$

Compute and plot each of the following convolutions:

(a) $y_1[n] = x[n] * h[n]$ **(b)** $y_2[n] = x[n + 2] * h[n]$

(c) $y_3[n] = x[n] * h[n + 2]$

2.8. Determine and sketch the convolution of the following two signals:

$$x(t) = \begin{cases} t + 1, & 0 \leq t \leq 1 \\ 2 - t, & 1 < t \leq 2 \\ 0, & \text{elsewhere} \end{cases},$$

$$h(t) = \delta(t + 2) + 2\delta(t + 1).$$

Convolution: Exercise

2.2. Consider the signal

$$h[n] = \left(\frac{1}{2}\right)^{n-1} \{u[n+3] - u[n-10]\}.$$

Express A and B in terms of n so that the following equation holds:

$$h[n-k] = \begin{cases} \left(\frac{1}{2}\right)^{n-k-1}, & A \leq k \leq B \\ 0, & \text{elsewhere} \end{cases}.$$

2.3. Consider an input $x[n]$ and a unit impulse response $h[n]$ given by

$$x[n] = \left(\frac{1}{2}\right)^{n-2} u[n-2],$$

$$h[n] = u[n+2].$$

Determine and plot the output $y[n] = x[n] * h[n]$.

2.4. Compute and plot $y[n] = x[n] * h[n]$, where

$$x[n] = \begin{cases} 1, & 3 \leq n \leq 8 \\ 0, & \text{otherwise} \end{cases},$$

$$h[n] = \begin{cases} 1, & 4 \leq n \leq 15 \\ 0, & \text{otherwise} \end{cases}.$$

Convolution: Exercise

2.21. Compute the convolution $y[n] = x[n] * h[n]$ of the following pairs of signals:

(a)
$$\left. \begin{aligned} x[n] &= \alpha^n u[n], \\ h[n] &= \beta^n u[n], \end{aligned} \right\} \alpha \neq \beta$$

(b) $x[n] = h[n] = \alpha^n u[n]$

(c)
$$\begin{aligned} x[n] &= \left(-\frac{1}{2}\right)^n u[n-4] \\ h[n] &= 4^n u[2-n] \end{aligned}$$

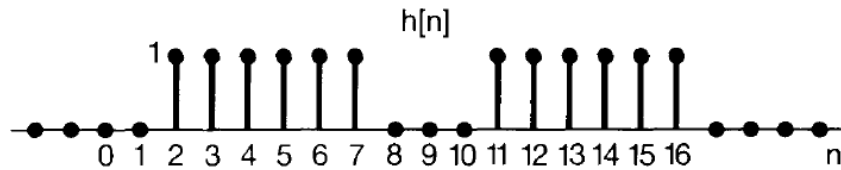
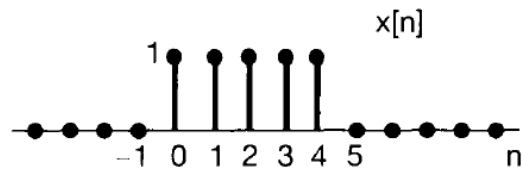

Convolution: Exercise

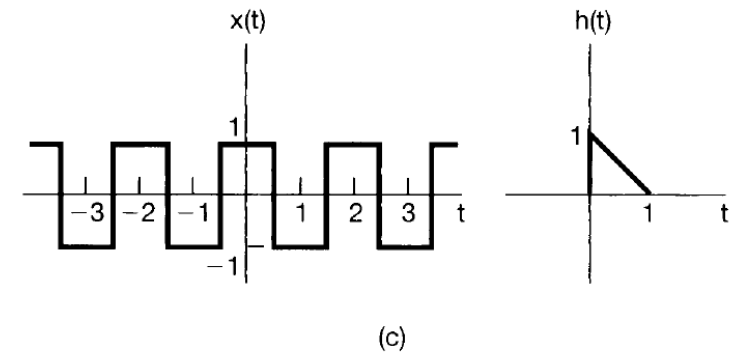
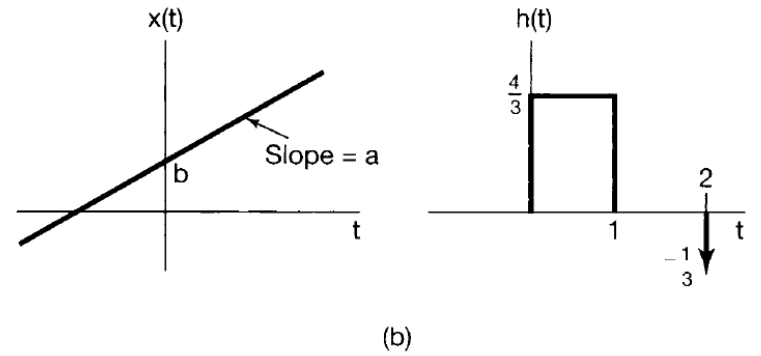
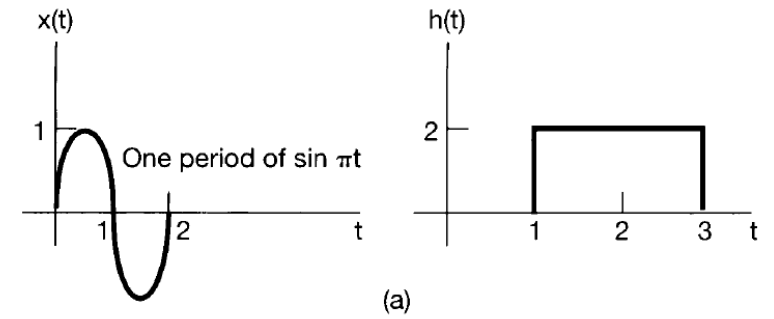

Exercises: Do at home

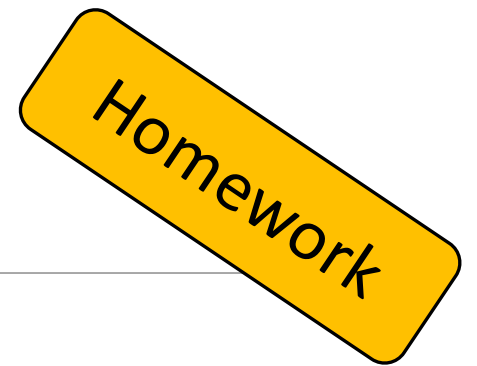

Book: Alan V. Oppenheim

Chapter 1 : System Properties

Chapter 2: Convolution

Examples

Basic Problems



Queen Mary
University of London